

What is an Improved Stove ?

Mrs Chitramaya Gharti-Magar's improved stove, Surkhet district, Nepal

The stove is the heart of the household. The stove turns our hard-earned farming produce into tasty and wholesome food. A well managed stove helps in other work also. If the stove isn't good, smoke in the kitchen will cause health problems and a lot of firewood will be used. In this chapter, a useful method is given to help solve these problems, which can bring big improvements in the kitchen, and from there to the household.

This method is called the **improved stove**. The improved stove can be cheaply made from local resources, and helps to remove smoke from the kitchen, while using less firewood.



Why make an Improved Stove ?

Differences between traditional and improved stoves

Traditional Stove or Tripod	Improved Stove
1. Uses a lot of firewood	1. Uses less firewood
2. Food cooks slowly	2. Food cooks quickly
3. Can only cook one item at a time	3. Can cook 2 items at a time
4. Cost of tripod	4. Don't need tripod
5. Smoke stays in kitchen	5. Smoke goes outside
6. Smoke damages health	6. No harm to health
7. Makes kitchen utensils dirty with soot	7. Doesn't make kitchen dirty
8. Small children can fall in the fire	8. No fear of small children falling in fire
9. Cooking makes the pots black with soot	9. Pots kept cleaner during cooking
10. Wind can make the fire jump	10. Stove not affected by wind
11. Can't make tripod from local resources	11. Stove made from local resources
12. Food cools quickly	12. Food stays hot longer

There are some disadvantages of the improved stove. These are :-

1. Large pieces of firewood can't be used;
2. The stove gives less light and direct heat in the kitchen;
3. The stove needs good maintenance, and from time to time you need to let the smoke into the kitchen (see page 22 for more information).



Other methods to reduce firewood use

While cooking, keeping the lid on pots helps to reduce firewood use. This also helps to conserve nutrients in the food.



Another method of conserving fuelwood is called the "**Haybox**". This can be made in a basket or box filled with tightly packed straw, as in the picture below, As soon as food (rice, pulses, vegetables, etc.) is brought to the boil on a normal stove, the pan is removed and placed in the hay box, and covered well. Here, there is no fire, but the food slowly keeps cooking, due to the conserved heat in the box. This takes 20-30 minutes longer than on a stove. After a while, take out the pan and the food is ready to eat.

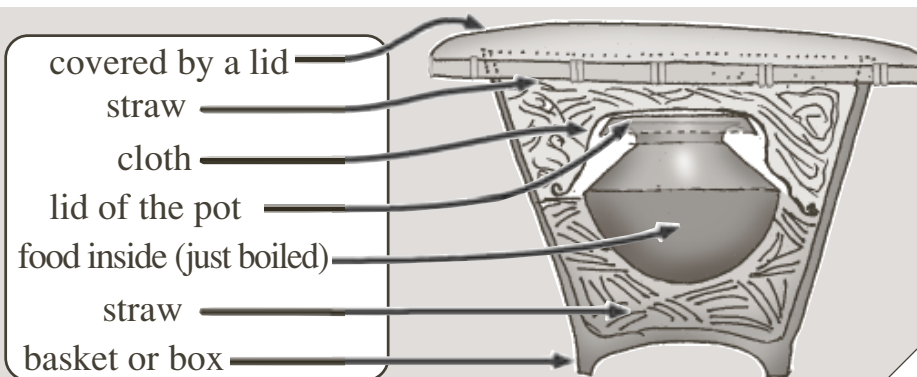

How To make an improved stove ?

Things to consider when making an improved stove

- get all the materials and tools ready first;
- map out the height of the kitchen's wall;
- map out the stove according to the needs of the family;
- allow for a place to clean the stove;
- the hole to allow smoke out should be out of the wind.

Materials needed to make an improved stove

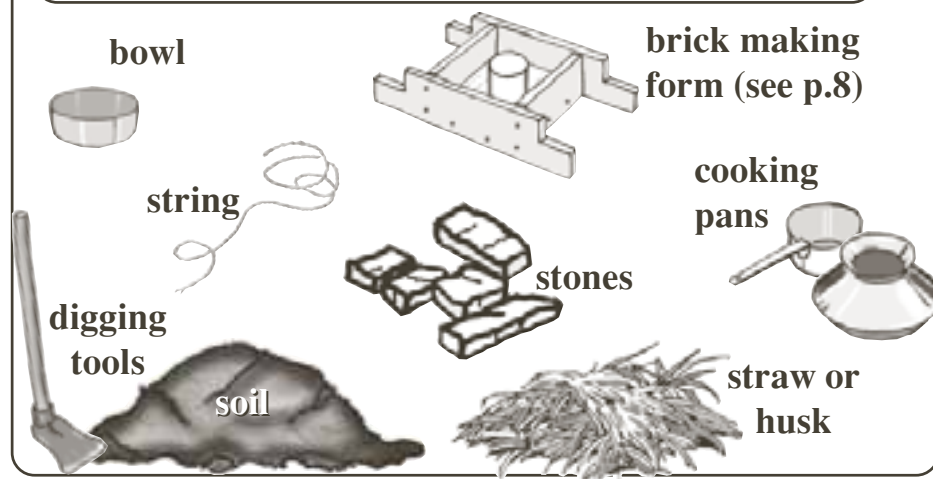

This Chapter's Author:

Mr Laxman Rana
Community Service Group,
Dahachaur 4, Surkhet, Nepal



Making the Improved Stove

An improved stove uses a chimney to pass the smoke out of the kitchen. There are 2 ways of making a chimney to do this :-

1. Making bricks using mud "pancakes"
2. Making bricks using a wooden form or mould

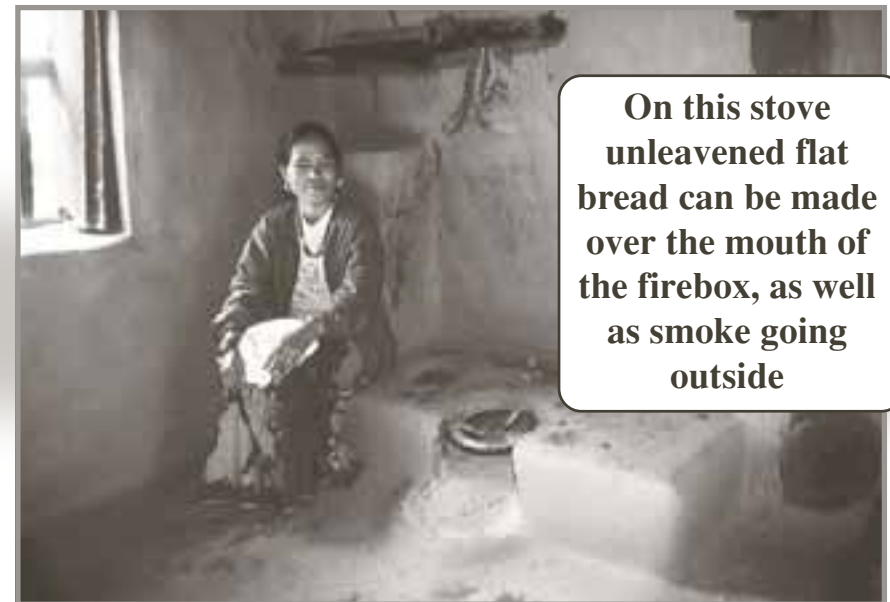

1. Making bricks using mud "pancakes"

In this method only clay, straw or rice husk, water and a small bowl are needed.

First mix the clay and the husk, or straw cut into 2 inch lengths, with water to make a stiff texture, like dough. →

see the pictures on the next page

Making bricks from clay "pancakes"

- 1 The pancakes should be 8 inches in diameter



- 2 The bowl should be 4 inches in diameter

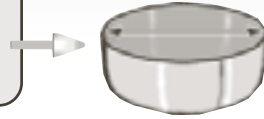

- 3 Place the bowl upside down on the pancake and press down, like this



- 4 The up-turned bowl will cut the clay



make 30-35 pancakes like this

- 5 This will make a hole the same shape and size as the bowl



2. Making a chimney using a wooden form or mould

One village will need only one of these forms

Materials needed to make the form

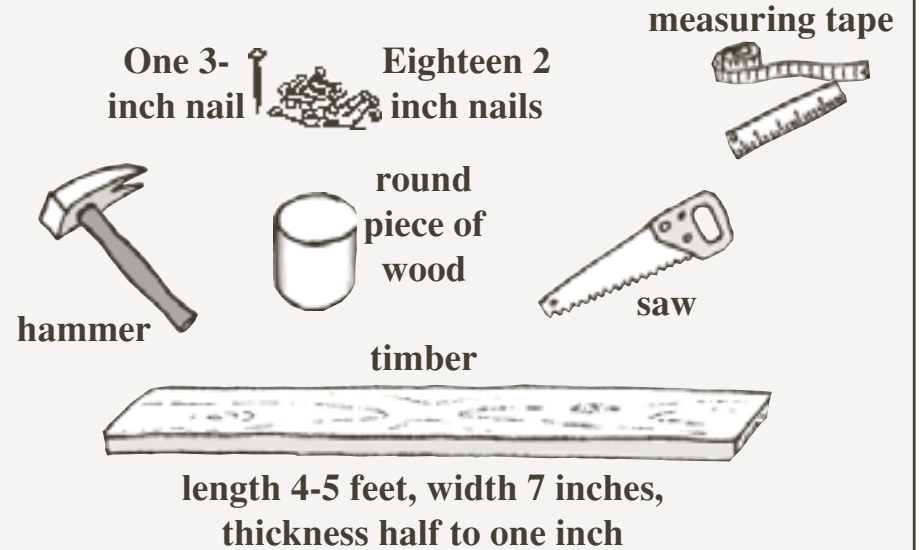

Cut the timber into pieces as shown here

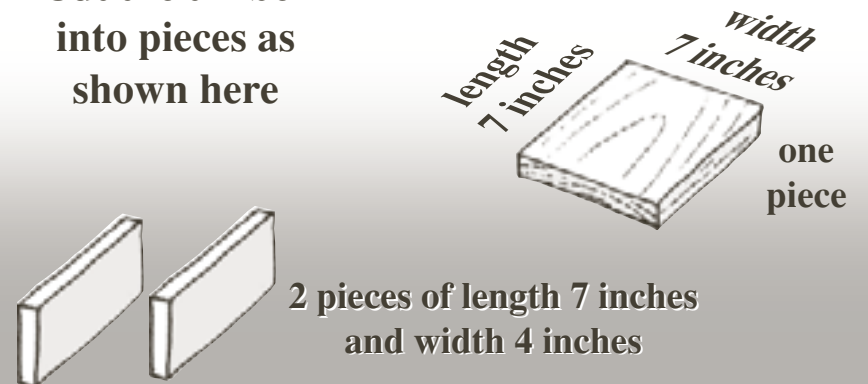

Join the 3 pieces of wood with nails, like this

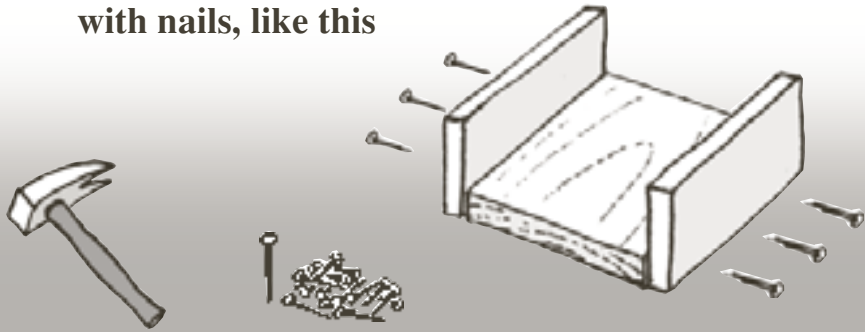

Saw 2 pieces of wood as shown below

length 15 inches, width 4 inches

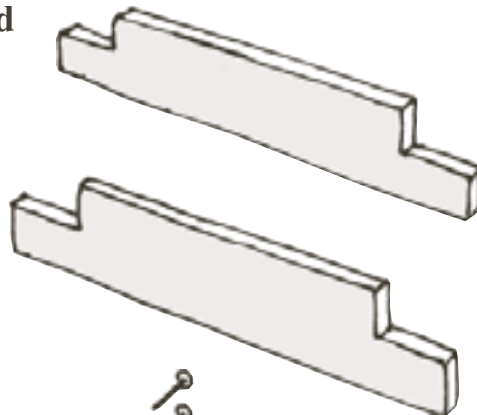

Join the pieces with nails, as shown here

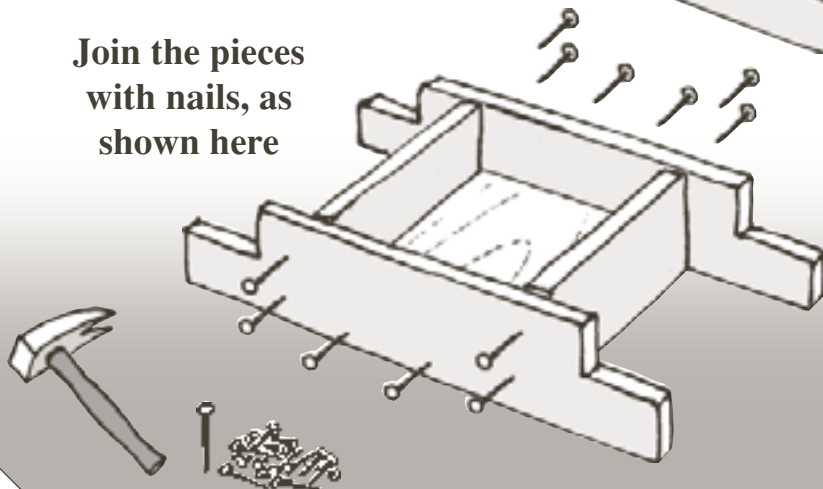

Now put the round piece of wood in the form

diameter 4 inches

length 3 inches

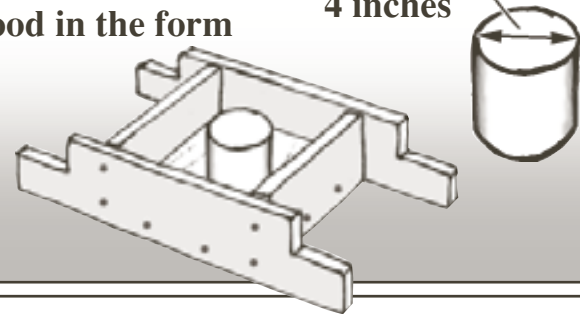

On the underside of the form make an 'X' between the 4 corners to find the centre

Holding the round piece of wood on the other side, nail in the long nail to hold it in place

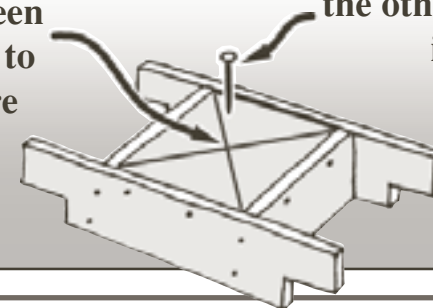

Making bricks in the Form

- mix the clay, husk or straw and water
- wash the form well
- scatter a little husk or straw in the form so it sticks to the wet wood

Now put the clay mix into the Form



Scrape off the excess clay to make level

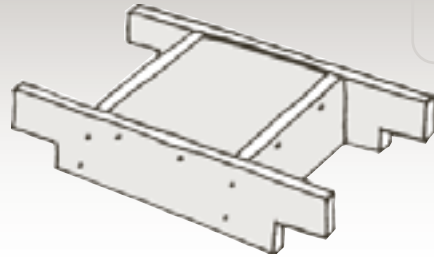
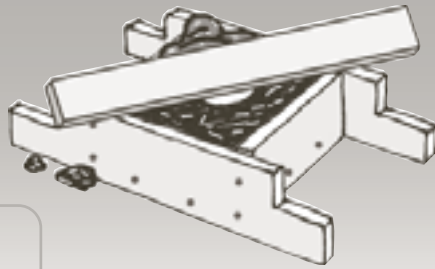

Turn the form upside down and tap gently

Leaving the clay brick on the ground, gently lift the form off

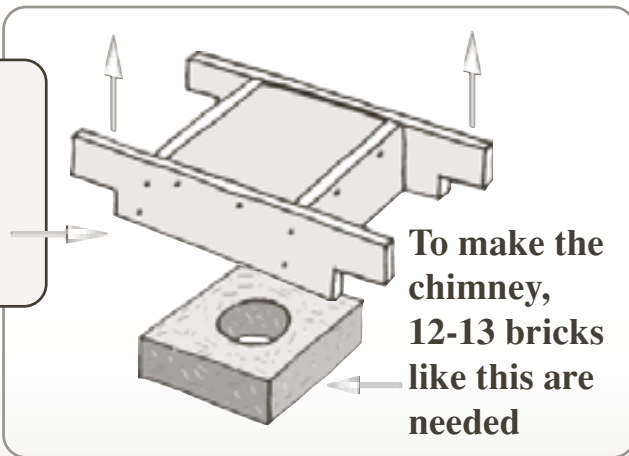

To make the chimney, 12-13 bricks like this are needed

Make 1 brick without a hole for the top of the chimney



Make 2 bricks looking like this

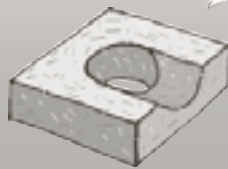

Let's see

How to make an improved stove

1



The form used to make the chimney

2

Rice husk, or chopped straw



3



Husk or straw mixed to a thick paste



4

Cleaning the Form

Pressing the clay/straw mix into the form

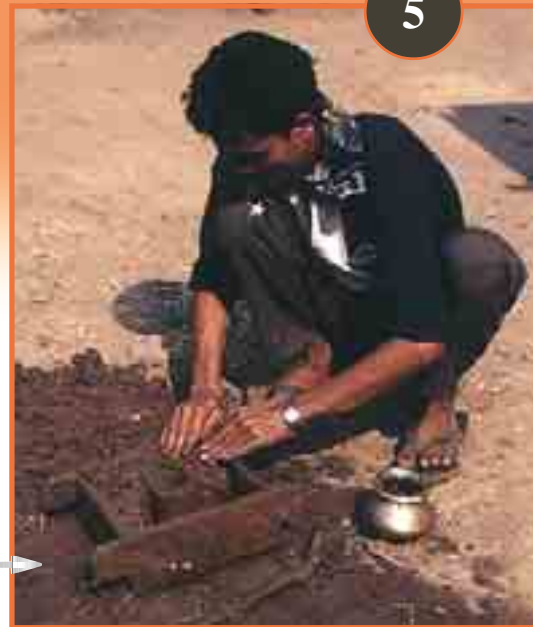

5



6

Chimney brick after removing from the form

12-13 of these bricks

2 bricks like this



1 brick without a hole

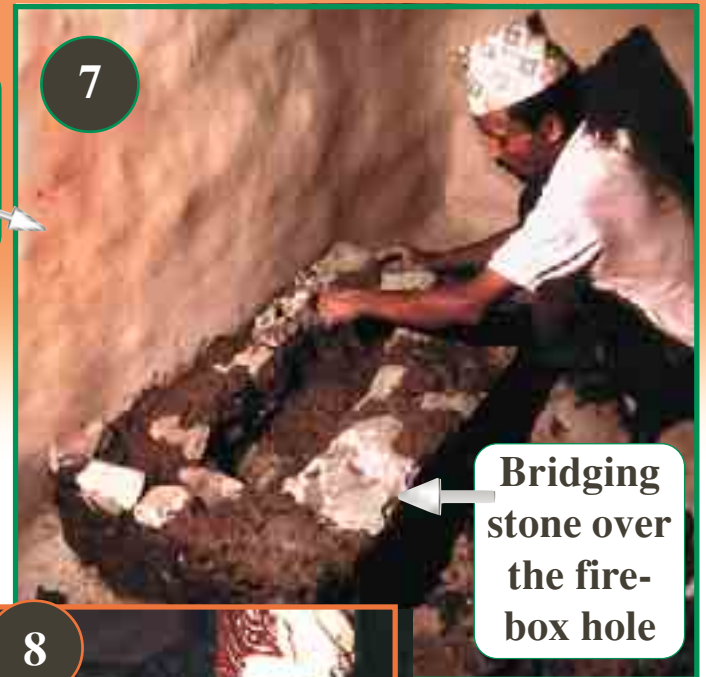

7

Starting to build the stove

Bridging stone over the fire-box hole

Smoke leaves here

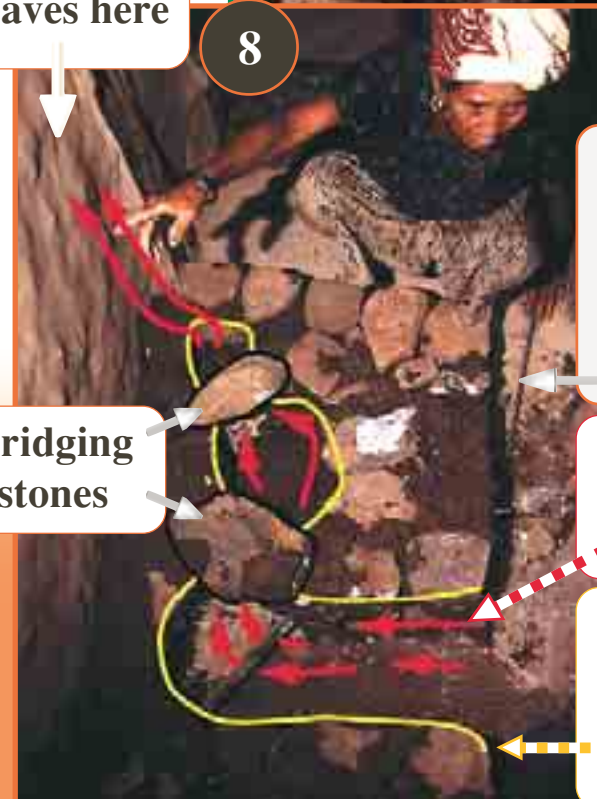

8

Build up the stove, leaving holes for pots and a path for smoke

Bridging stones

Red arrows show pathway for smoke

Yellow lines show empty spaces left inside the stove



In the below pictures is the process of building the stove in drawings

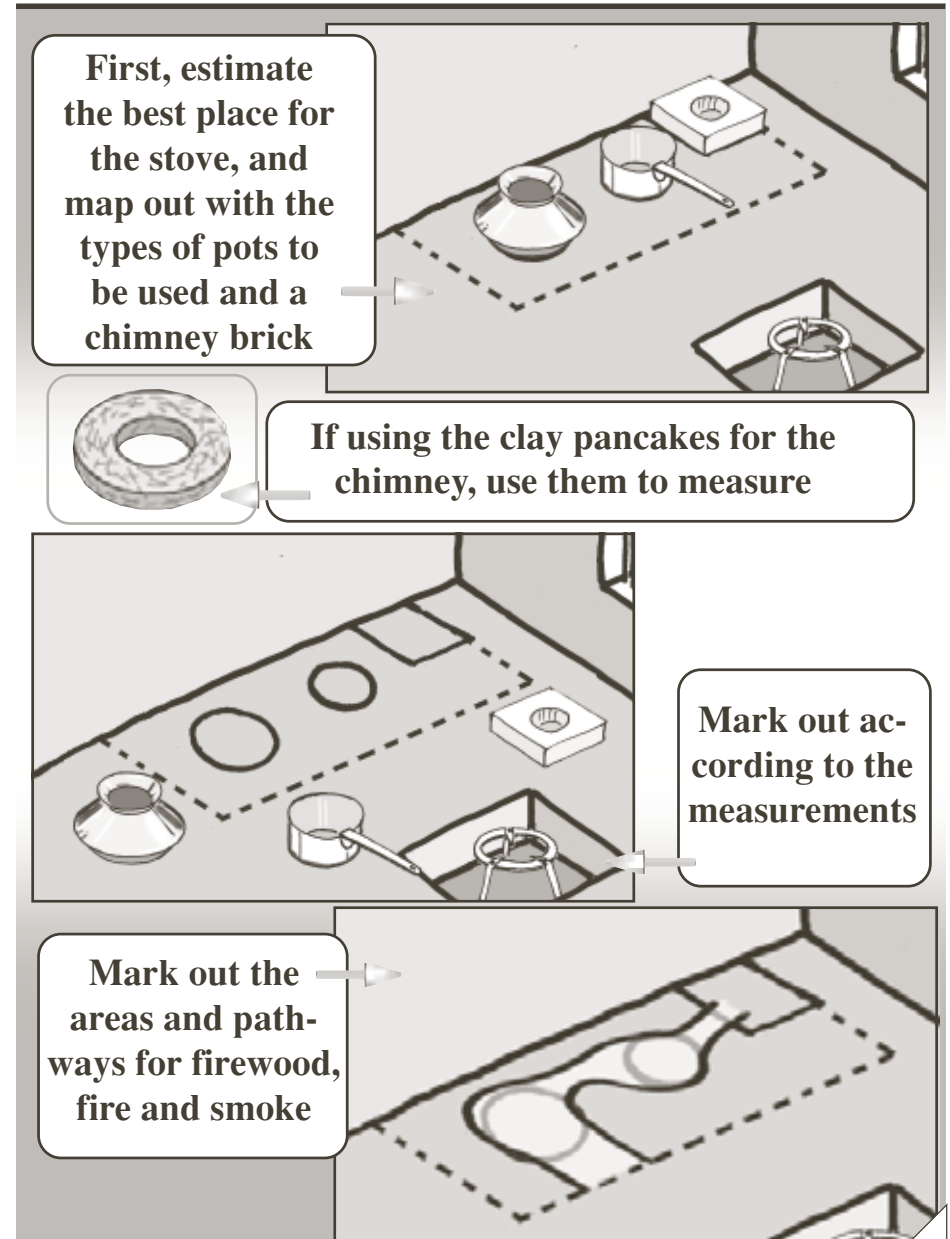

Start to build the walls according to the measurements

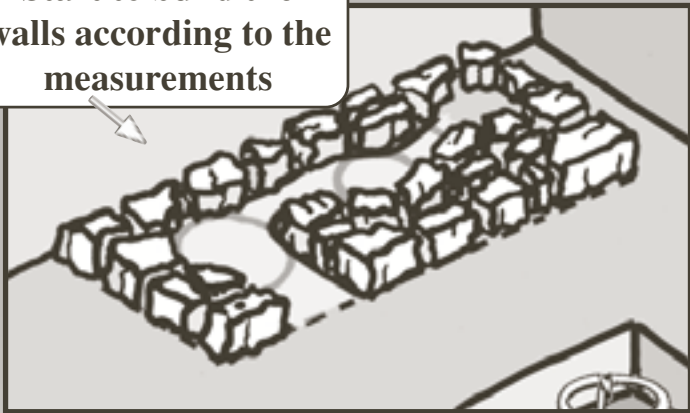

Iron rod

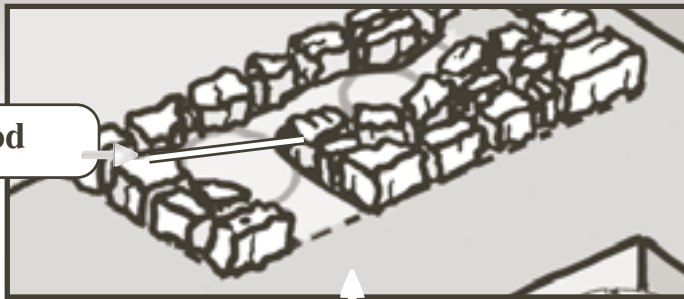

Use an iron rod if available. This sits inside the pot's hole and allows smaller pots to rest on it

Continue to build up the walls



Cooking area finished

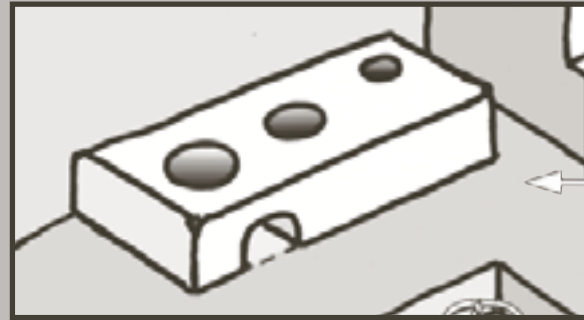

Inside the stove looks like this

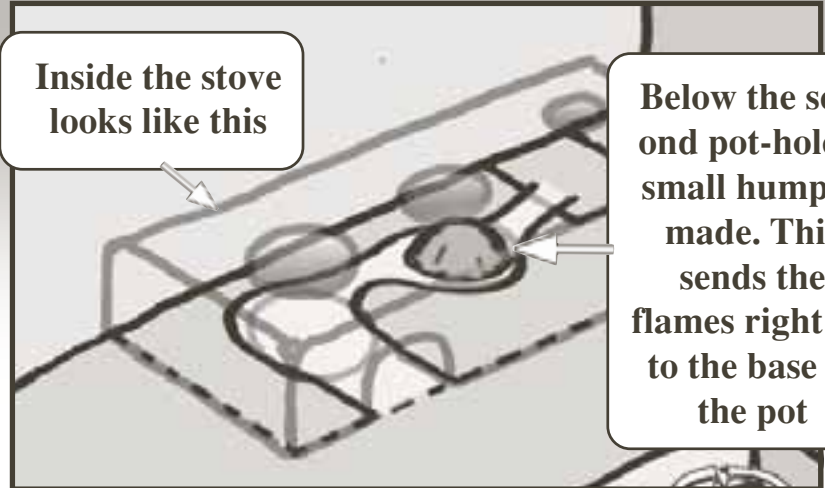

Below the second pot-hole a small hump is made. This sends the flames right up to the base of the pot

This shows the inside when a fire is burning

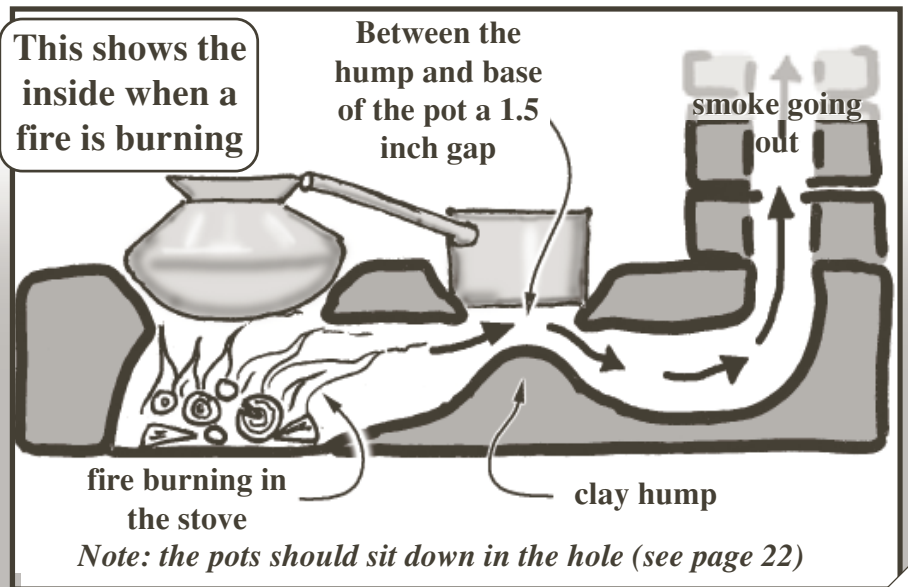

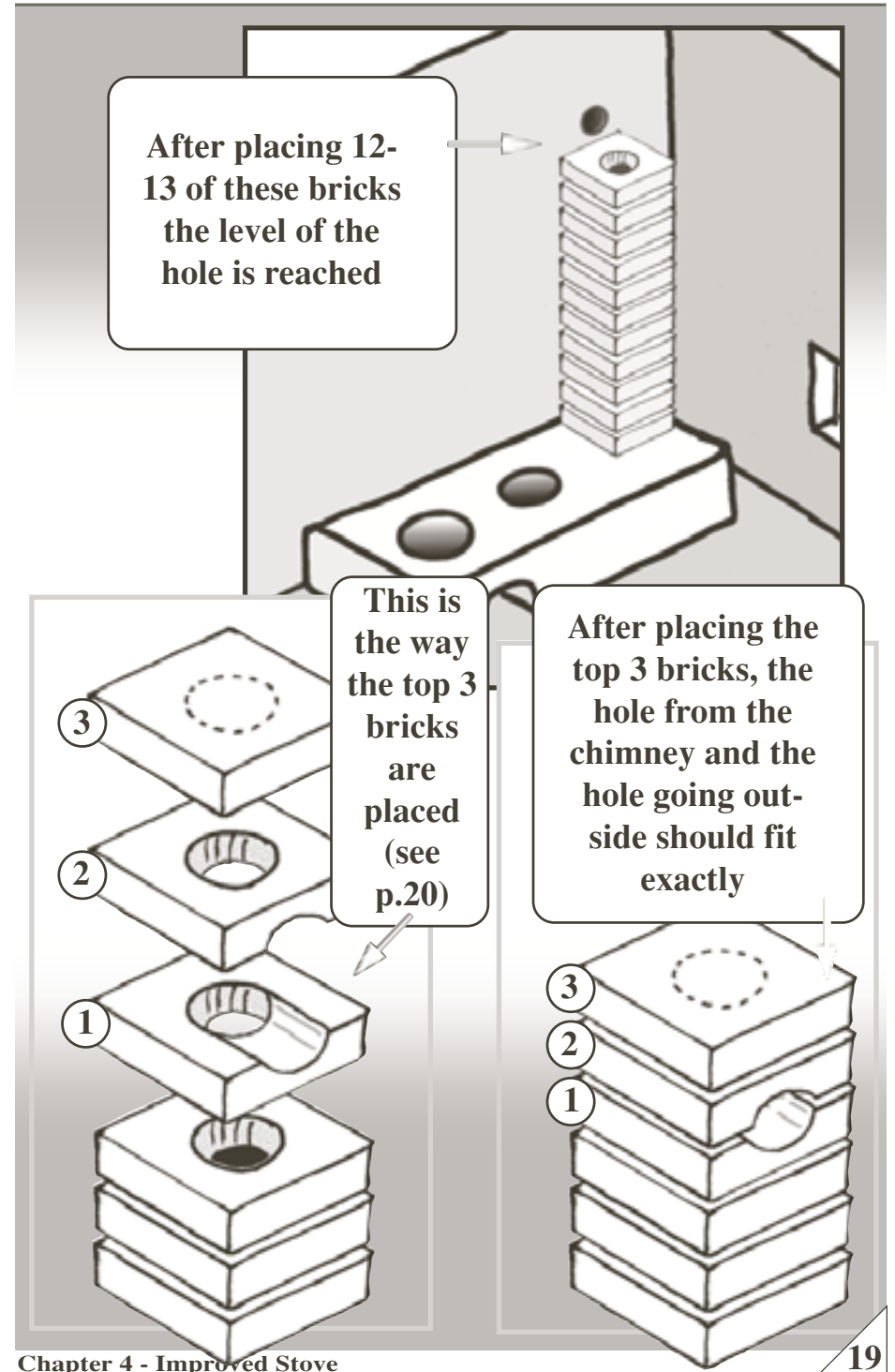
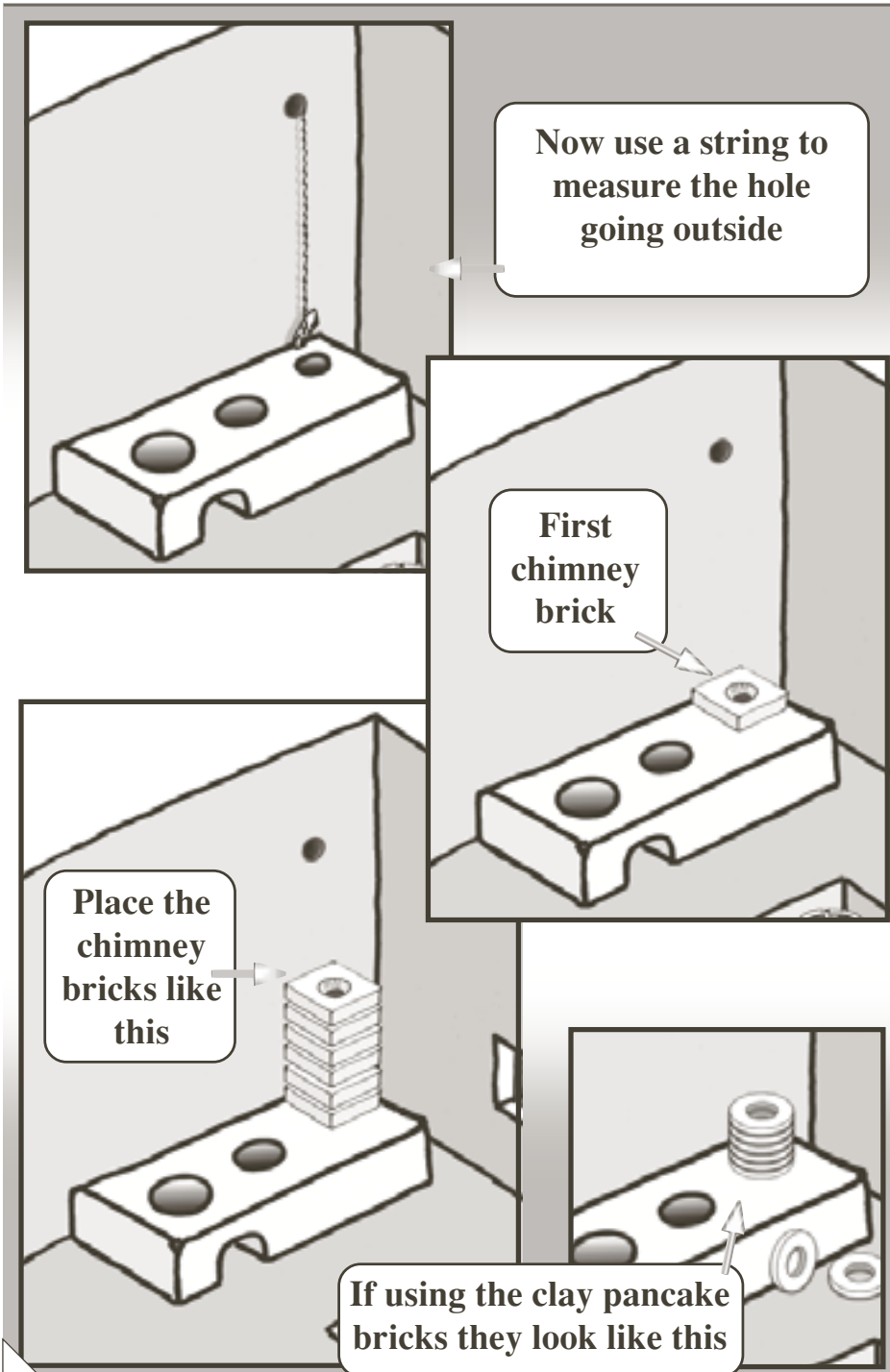

The method to place the top 3 bricks is shown below

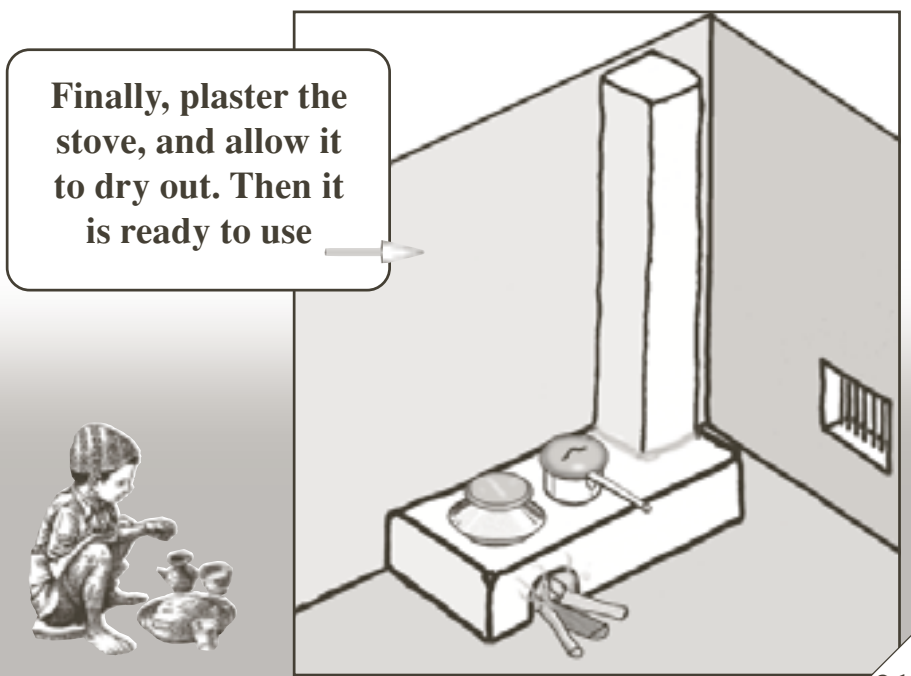
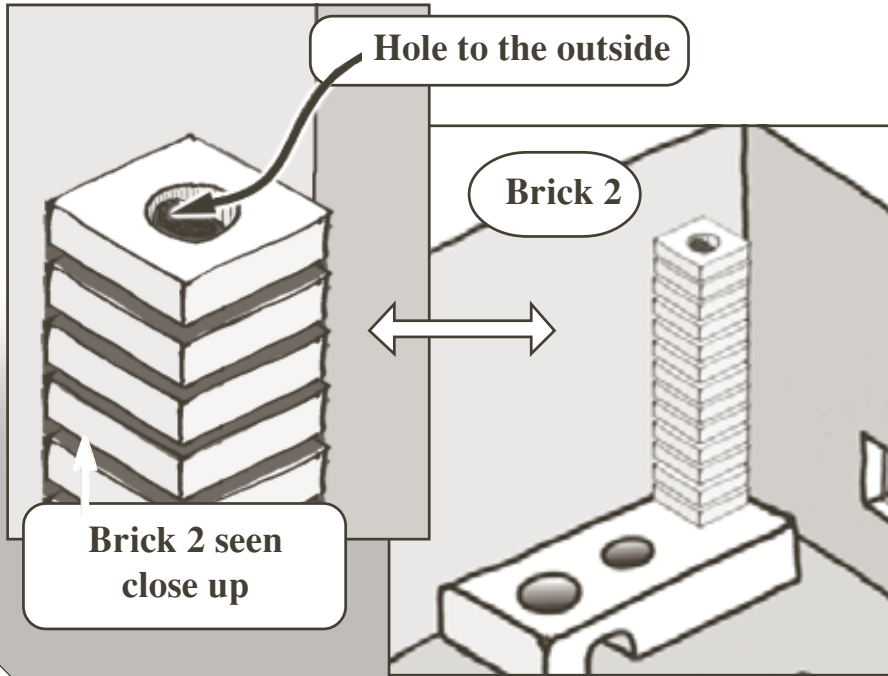
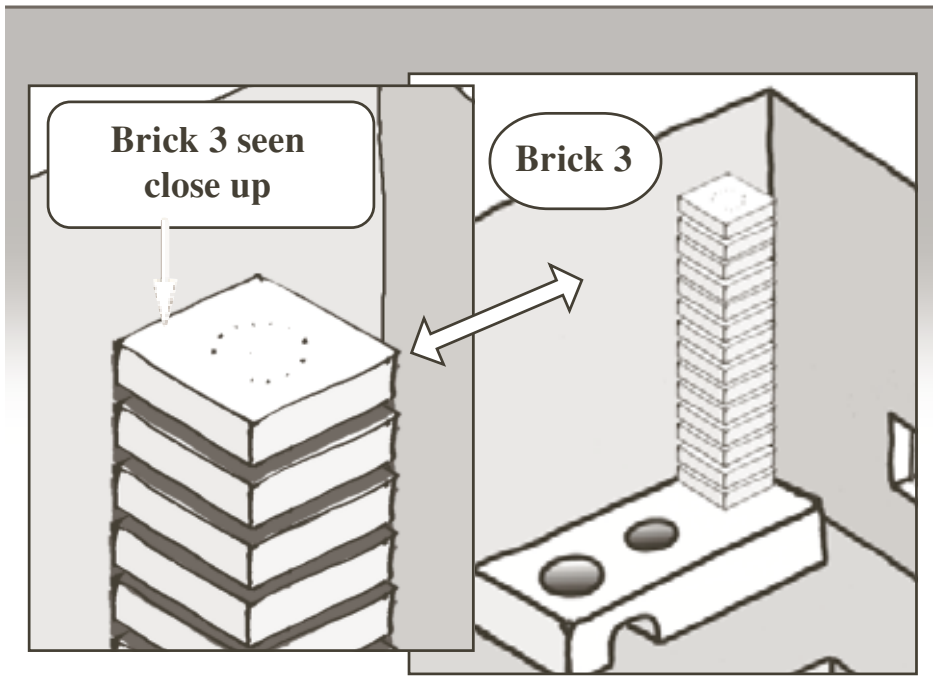
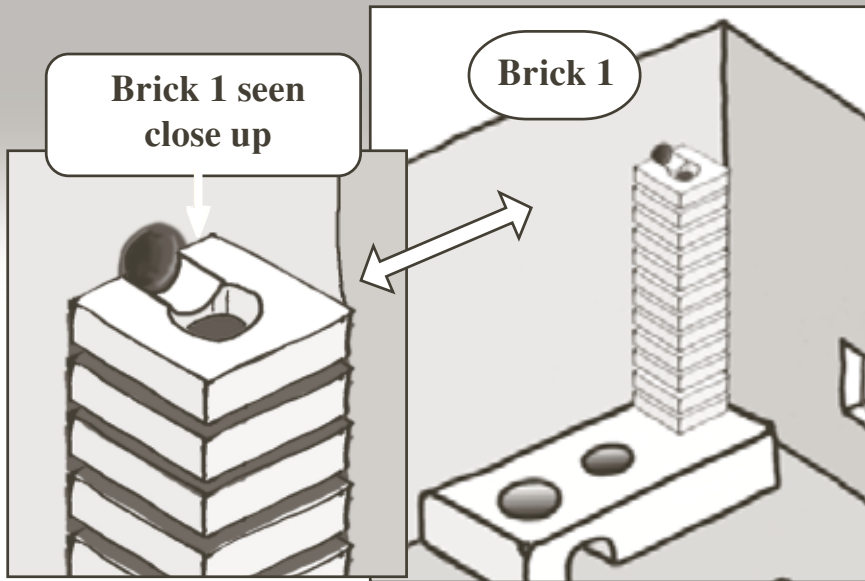

Things to pay attention to when using the stove

In this picture the stove is being used correctly - the pot is low in the hole where more flames reach the base, and smoke can escape.



In this picture the stove is not used well - because the pot does not sit low in the hole, the flames do not reach close. In this way food cooks slowly. This is due to using the wrong size pots for the hole.



If the pots are the wrong size for the hole then, as in the diagram, put 3 small stones under the pot to draw the flames up where they heat the base of the pot. But this allows more smoke into the kitchen.

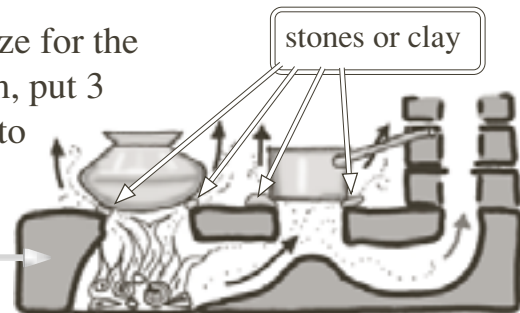

A well made stove, used correctly, will not let smoke out into the kitchen. But this can cause another problem in that the smoke helps to control various pests which otherwise can damage timber, stored grain and seed. Smoke, protects the timbers from these pests. Therefore, every few days smoke needs to be let into the house.

Cleaning the Improved Stove

- watch if smoke is passing or not
- watch if food is cooking fast or slow
- clean the chimney every week or 2 (see below)
- plaster the stove daily (do not use dung)
- measure how much firewood is used

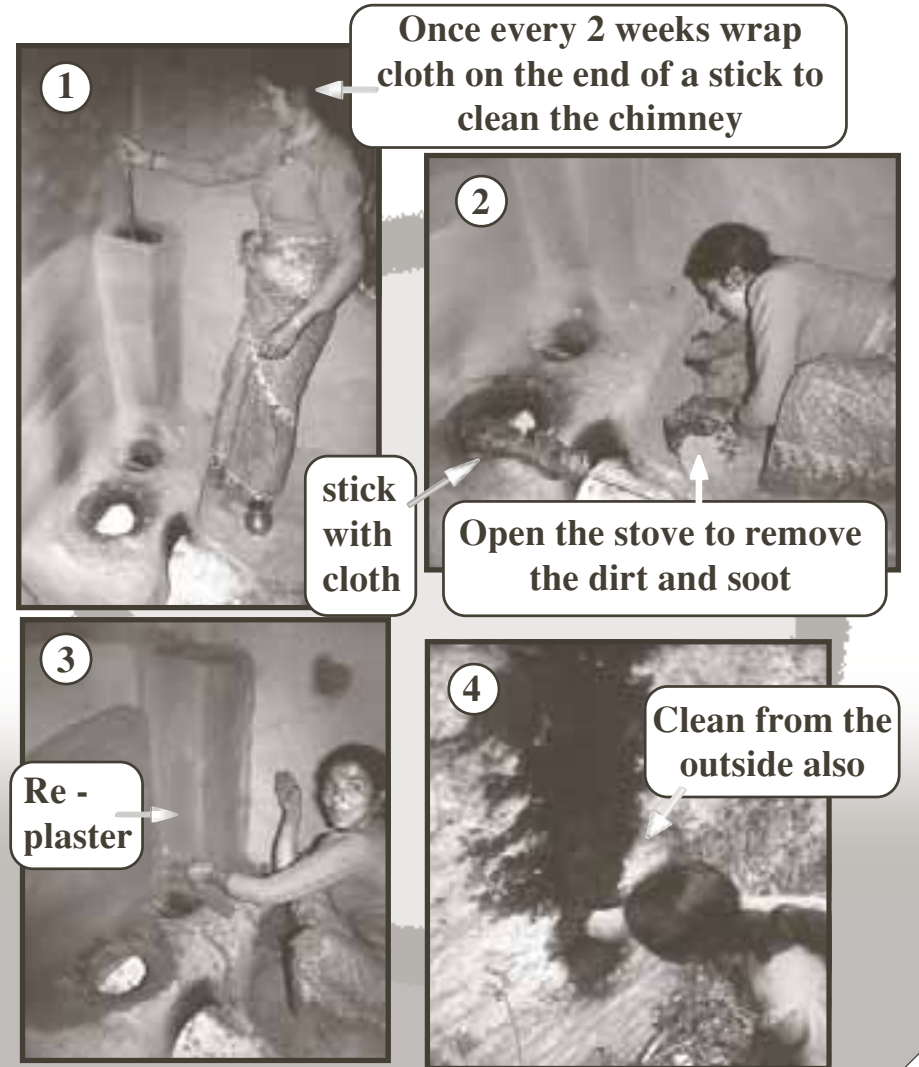

Farmers' Experience

Mrs Chitramaya Gharti Magar

Grihasthi Communications

From Nepal, Surkhet district, Dahachaur - 4, and member of "Ritu Laligurans" and "Hariyali" women's group Mrs Chitramaya Gharti Magar has made an improved stove. Now let's read about what she says.



Mrs Chitramaya Gharti Magar

“ Because smoke affects our health it's important to make the smoke go outside. In the improved stove less firewood is also used, so time is saved collecting fuel as well as helping to protect the forest. To make this stove stone, clay, rice husk and a form to make the chimney is all that's needed. We didn't have a form in our village, so I used a bowl to make 35-36 clay pancakes. The form also uses more clay. Making the pancakes needs less clay and you don't need the form, so I made up this method. There's no smoke from my stove, and it uses less firewood. Once cooked, the food stays warm a long time left on the stove. There are no flies and the food can't burn. Also, the pans don't get so black with soot. Now, I want teach others in the village how to make the stove. ”

